



HID540 - Touch-Free Ice & Water Dispenser

Nugget Ice Machine / Dispenser



HID540A-1 with optional KLP24A legs



Sealed, maintenance-free bearings ensure maximum reliability and contribute to a long machine life



Touch-free infrared sensor dispensing option, providing more sanitary operation



User controlled antimicrobial push-button dispensing option, providing quick and efficient operation

The Meridian® Difference

Sanitation:

- Touch-free, infrared dispensing of ice and water eliminates the need to physically touch the dispenser for more sanitary operation
- AgION® and other antimicrobial compounds are molded into key components to help inhibit the growth of microbes, bacteria, mold and algae
- Fully removable bin, spouts, air filter, sink, and grill allow for easy cleaning and maintenance
- Sealed refrigeration system minimizes outside airborne contamination
- Front accessible, removable air filter makes cleaning more convenient

Reliability & Ease of Use:

- Sealed, maintenance-free bearings reduce preventative maintenance and ensure maximum reliability
- Produces Scotsman's chewable H² Nugget Ice which is slow-melting and designed for reliable dispensing
- Space-maximizing design – the industry's smallest operational footprint relative to capacity, featuring specially designed contoured sides for enhanced breathability
- Unit-specific QR code for quick access to service manuals and warranty history
- Durable stainless-steel evaporator and exterior panels, plus larger sink opening and dispensing area
- Enhanced service features - Intuitive LED diagnostic lights reduce service time and convenient USB drive allows for fast software updates
- Industry-leading energy and water efficiency along with quieter operation



24 Hour Volume Production

Air Cooled		Water Cooled	
70°F/21°C 50°F/10°C	Air Water	90°F/32°C 70°F/21°C	70°F/21°C 50°F/10°C
500/227 lb/kg		365/166 lb/kg	500/227 lb/kg
			400/181 lb/kg



Specifications

Model Number	Condenser Unit	Dispensing Method	Storage Capacity lb/kg	Basic Electrical Volts/Hz/Phase	Max. Fuse Size or HACR Circuit Breaker (amps)	Min. Circuit Amps	Energy Consumption kWh/100 lb 90°F(32°C)/70°F(21°C)	Water Usage Gallons/100 lb (liters/45.4 kg)	
								Potable 90°F(32°C)/70°F(21°C)	Condenser 120/454.3
HID540A-1	Air	Touch-Free Sensor	40/18.1	115/60/1	15	Cord	5.50	12/45.5	-
HID540AB-1	Air	Button Activated	40/18.1	115/60/1	15	Cord	5.50	12/45.5	-
HID540AW-1*	Air	Touch-Free Sensor	40/18.1	115/60/1	15	Cord	5.50	12/45.5	-
HID540W-1	Water	Touch-Free Sensor	40/18.1	115/60/1	15	Cord	4.30	12/45.5	120/454.3
HID540WB-1	Water	Button Activated	40/18.1	115/60/1	15	Cord	4.30	12/45.5	120/454.3

*Wall mount configuration. Does not have or accept a drip tray. Unit designed to be installed over existing sink.



H²Nugget Ice

Chewable, slow-melting ice that allows for more reliable dispensing.



3/4" x 5/16" x 3/8"
(1.9 x 0.8 x 0.95 cm)



Certification



Warranty

- 3 years parts and labor.
- 5 years parts on the compressor and condenser.
- Warranty valid in North, South & Central America for commercial installations.
- Contact factory for warranty in other regions.
- Residential Applications: 1 year parts and labor

HID540 - Touch-Free Ice Machine / Dispenser

HID540 - Touch-Free Ice & Water Dispenser

Nugget Ice Machine / Dispenser

Without Wall Mount: HID540A(B) & HID540W(B)

Installation Note: Allow 6" space at left, back and right side for ventilation and utility connections.
All models include 7.5' power cord with NEMA 5-15P plug.

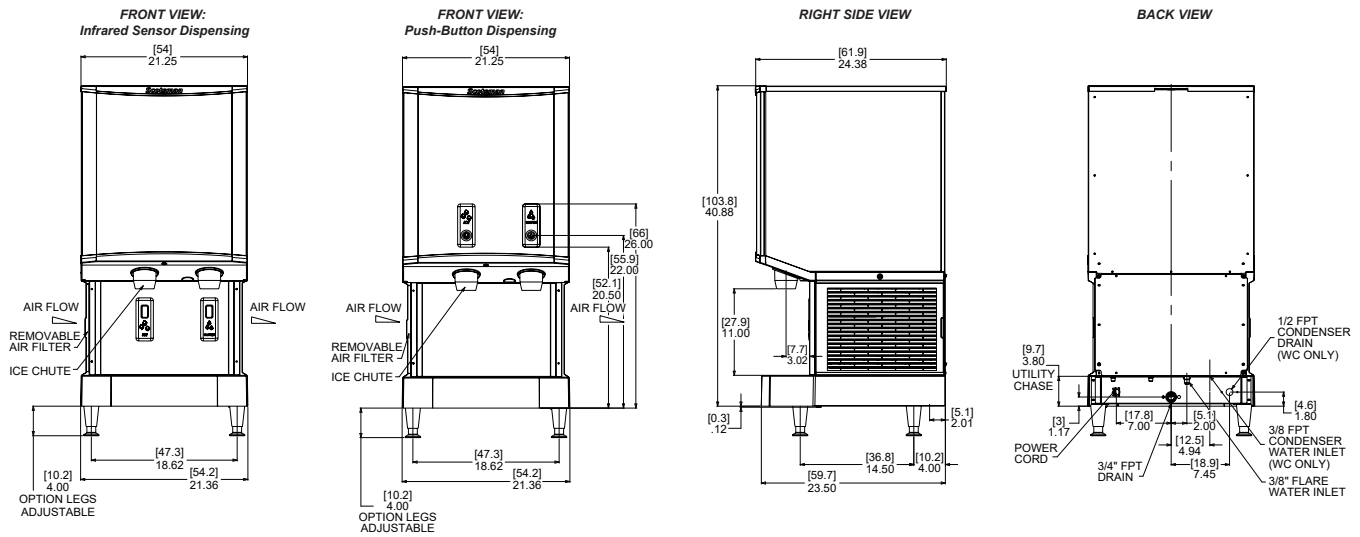

With Wall Mount: HID540AW

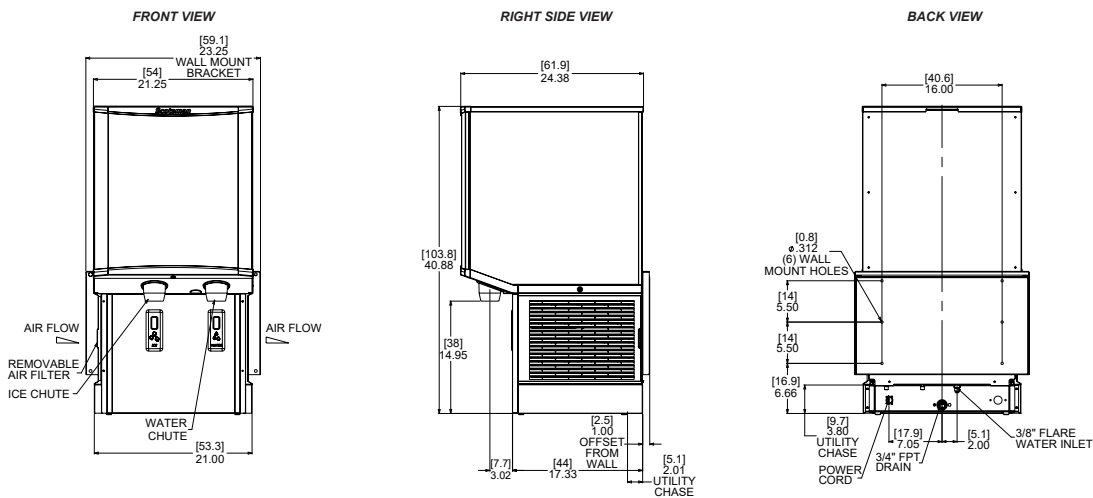

HID540 - Touch-Free Ice Machine / Dispenser



All Models

Dimensions (W x D x H):

Unit:

- HID540A(B)-1: 21.25" x 24.38" x 41"
- HID540AW-1: 23.25" x 24.38" x 41"
- HID540W(B)-1: 21.25" x 24.38" x 41"

Shipping Carton:

- HID540A(B)-1: 24.25" x 27.13" x 47.5"
- HID540AW-1: 24.25" x 27.13" x 47.5"
- HID540W(B)-1: 24.25" x 27.13" x 47.5"

Shipping Weight: HID540A(B)-1: 215lb / 98kg
 HID540AW-1: 220lb / 100kg
 HID540W(B)-1: 215lb / 98kg

BTUs per hour: 6,800

Refrigerant: R-404A



Accessories

Model Number	Description
KLP24A	4" Adjustable legs, box of 4, plastic with metallic foot.
HST21-A	Machine stand for HID525 and HID540, with locking reversible door and shelf.
HST21B-A	Machine stand for HID525 and HID540, basic version.

Scotsman recommends all ice machines have water filtration. See Scotsman water filter specification sheet for details.



Operating Requirements

	Minimum	Maximum
Air Temperatures	50°F (10°C)	100°F (38°C)
Water Temperatures	40°F (4.4°C)	100°F (38°C)
Potable Water Pressures	20 PSIG (1.4 bar)	80 PSIG (5.5 bar)
Electrical Voltage	-5%	+10%

Specifications and design are subject to change without notice.